

***ENS26 Automatic Isolation Unit
Installation Manual***

Issue 09/2005

UfE Umweltfreundliche Energieanlagen GmbH
Joachim-Jungius-Straße 9
D-18059 Rostock

Tel.: +49 3 81 / 405 97 05
Fax: +49 3 81 / 405 97 03
E-mail: post@ufegmbh.de
web: www.ufegmbh.de

**Note**

If you have any queries and need to contact UfE GmbH, always have the serial number close to hand in order to make reference to it. We do not claim the documentation is free of errors and mistakes. Please inform UfE GmbH of any errors found in the documentation.

© Copyright

This Installation Manual is the copyright of UfE GmbH.
This manual is intended for the electrician. It contains instructions and information which must not be copied, distributed or transferred by technical data methods nor used for the purpose of competition, either as an entirety or as extracts, without the necessary authorisation.
Contravention could lead to prosecution and obligation to pay damages.
All rights reserved, particularly in the case of patent application or other registrations.
We reserve the right to make technical modifications without notice.

**Note**

The ENS26 isolation unit and the measuring method are protected by patent.

1	Safety	4
1.1	General information	4
1.2	Safety symbols used in this operating manual	4
1.3	Obligations	5
1.3.1	Obligations of the proprietor	5
1.3.2	Obligation of personnel.....	5
1.4	Guarantee and liability.....	6
1.5	Accident prevention regulations	7
1.6	Intended use.....	8
1.6.1	Exclusive purpose	8
1.6.2	Observe information and regulations.....	8
1.7	Installation and connection.....	9
1.8	Operation	10
1.9	Rating plate and CE symbol.....	11
2	Connections and Indicators	12
2.1	Connections	12
2.2	LCD display and LEDs	13
3	Mechanical Installation	14
3.1	Transport and unpacking.....	14
3.2	Conditions for installation	14
3.3	Preparing the electrical/meter cabinet.....	15
3.4	Mounting on the top hat rail.....	15
3.5	Removing from the top hat rail	16
4	Electrical Connections	17
4.1	Basic configuration.....	17
4.2	Circuitry.....	17
4.3	Disconnection.....	18
5	Function Test	19
5.1	Switching the system on.....	19
5.2	Indicators during operation.....	19
6	Technical Data	20

1 Safety

1.1 General information

This chapter contains information on safety and rules of conduct. It is essential to observe the information and rules so that any residual risks represented by the product do not lead to a fault or an accident.

The device must be connected to the local power supply. Therefore, all the normal risks involved in the use of electrical power are present here, too.

1.2 Safety symbols used in this operating manual

The following symbols are used at the relevant points throughout this manual. Pay strict attention to the information provided in these sections and proceed with the utmost care.

Meaning of the safety symbols:



Danger

This symbol indicates the risk of fatal or personal injury if certain rules of conduct are disregarded. When this symbol appears in the operating manual, take all the necessary safety precautions.



Attention

This symbol indicates the risk of property damage as well as financial and legal disadvantages (e.g. loss of rights to claims under the terms of guarantee, liability, etc.).



Note

This symbol indicates important information on working efficiently, economically and ecologically.

1.3 Obligations

1.3.1 Obligations of the proprietor

The proprietor is obliged only to allow suitably trained personnel to work with the ENS26 isolation unit who

- are familiar with the basic regulations on safety and accident prevention,
- have read the operating manual, the chapter on safety and the safety symbols, have understood them and confirmed this with their signature.

The proprietor must always ensure the entire product documentation is at the disposal of operating personnel.

**Danger**

The proprietor bears the responsibility for safety. This responsibility cannot be delegated.

1.3.2 Obligation of personnel

Personnel must:

- be in possession of a license to connect electronic equipment to the public electricity supply,
- always ensure for themselves that third-parties and the equipment are safe,
- maintain the safety and connection regulations of the power supply provider,
- have read and understood the operating instructions, the chapter on safety and warning labels,
- observe the applicable regulations concerning industrial safety and accident prevention.

**Danger**

This concerns the safety of yourself and other persons in the vicinity of the ENS26 as well as safety when working with the mains electricity supply.

1.4 Guarantee and liability

Our "General Terms of Sale and Delivery" apply. The proprietor has claim to these on conclusion of the contract at the latest. Rights to claims under the terms of guarantee and liability in respect of persons and property are considered void when they are the result of one or more of the following causes:

- Unintended use of the ENS26,
- Improper start up, operation and service of the ENS26,
- Failure to observe information in the overall documentation in respect of
 - installation, connection
 - starting up
 - operation
 - cleaning/servicing
- Unauthorised constructional modifications to the ENS26,
- Damage through overvoltage, overload, short circuit, mechanical interference, moisture,
- Case of catastrophe caused by foreign body or Act of God.

**Attention**

No modification may be carried out on the ENS26 without the approval of the manufacturer.

**Attention**

Never attempt to repair the device yourself. All rights to claims under the terms of guarantee are annulled in the case of tampering.

1.5 Accident prevention regulations

Any faults which occur that affect safety must be eliminated immediately. The ENS26 may not be operated until the fault has been cleared.



Danger

Solar modules conduct electricity as soon as they are exposed to daylight. Observe this when laying and connecting the cables and take the necessary precautions.



Danger

It is forbidden to open the unit. The box can continue to conduct dangerous residual voltage some minutes after being switched off.

1.6 Intended use

The ENS26 has been built according to state-of-the-art technology and accepted safety regulations.

However, when the unit is used, there remains a risk of fatal and personal injury to the user and third-parties as well as impairment of the unit and other property damage.

1.6.1 Exclusive purpose

The ENS26 is exclusively intended for monitoring voltage, frequency and impedance of one phase of the electricity network at the feeding point of a power generating system. On detecting over- and undervoltages, frequency deviation or impedance jumps, the ENS26 disconnects all poles of the feeding point from the public electricity supply.

Any other use is considered unintended use. The manufacturer is not liable for any consequential damage in such cases.

1.6.2 Observe information and regulations

Intended use also includes

- observing all information provided in this manual and
- maintaining the connection and installation conditions prescribed by the manufacturer.

1.7 Installation and connection

The unit is designed for installation in an electrical cabinet or meter cabinet. If there is insufficient space in the cabinets available, a separate cabinet must be provided for the ENS26 and contactors.

Never place the cabinet containing the ENS26 above or in the vicinity of a heater. Pay attention to sufficient ventilation.

Connection to the public electricity supply may only be performed by a properly qualified electrician. The safety regulations of the electricity supply authority must be observed.

Do not place anything on the connection cable. Lay all the cables so that they do not present a risk of tripping. Fix all cables to the wall, ceiling etc.

Pay attention to the cable cross-section requirements for all connection cables.

Never attempt to repair the unit yourself. Opening the unit can expose components conducting dangerously high levels of voltage. Repairs may only be made by the manufacturer or an authorised specialist.



Danger

It is forbidden to open the unit. The unit can continue to conduct dangerous residual voltage some minutes after being switched off.

1.8 Operation

Operation of the ENS26 is impermissible:

- for monitoring tasks for which the unit is not designed,
- when using accessories which have not been approved by the manufacturer,
- when the proprietor has made constructional modifications.

Functional faults must be analysed immediately. If necessary, the proprietor must request specialist assistance. The equipment may only be put into operation again when there is no doubt about its safety.

The ENS26 is intended for operation at room temperatures between - 20 °C and + 40 °C (also refer to Chapter 5, Technical Data).

Contact a suitably trained electrician or the manufacturer in the following cases:

- connection cable is damaged,
- liquids or foreign bodies have got inside the unit,
- the unit has been exposed to water or rain,
- the unit has fallen down or is mechanically damaged,
- the unit behaves in a way indicating a fault (e.g. indication or message on the optional LCD, constant switching).

1.9 Rating plate and CE symbol

The manufacturer has provided the following information on the ENS26 at the positions indicated:

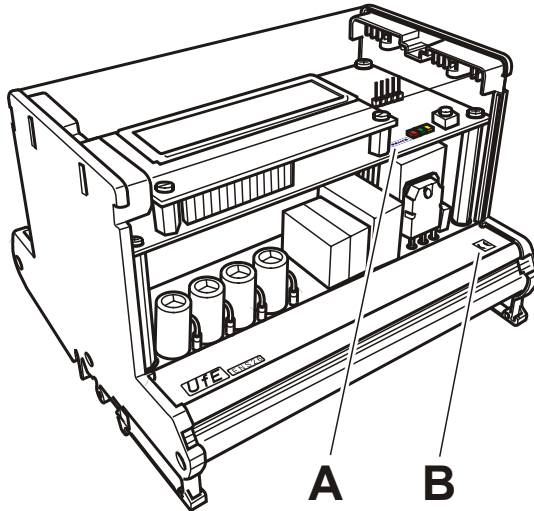

A) Serial number

The manufacturer's serial number for the ENS26 is provided at this point.

B) CE symbol

The CE symbol is located at the bottom right corner of the front side:



Note

Always make reference to the ENS26 serial number in the case of inquiries, orders and contracts. This simplifies communication with the manufacturer and prevents errors when processing requests.

2 Connections and Indicators

2.1 Connections

The following connections are provided at the top edge of the ENS26:

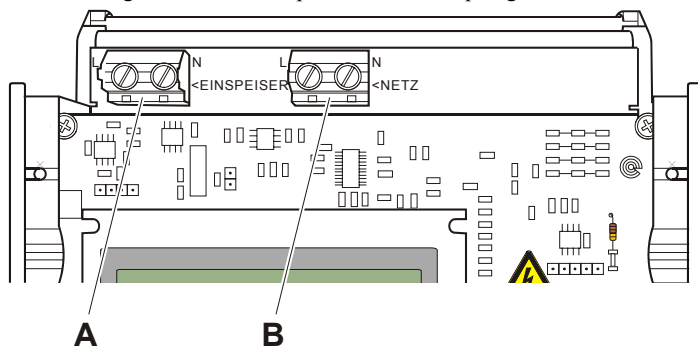

- A** 2 connection terminals to connect one phase and the neutral conductor (feeding unit)
- B** 2 connection terminals to connect one phase and the neutral conductor (mains)

2.2 LCD display and LEDs

The following indicators are provided on the front side of the ENS26:

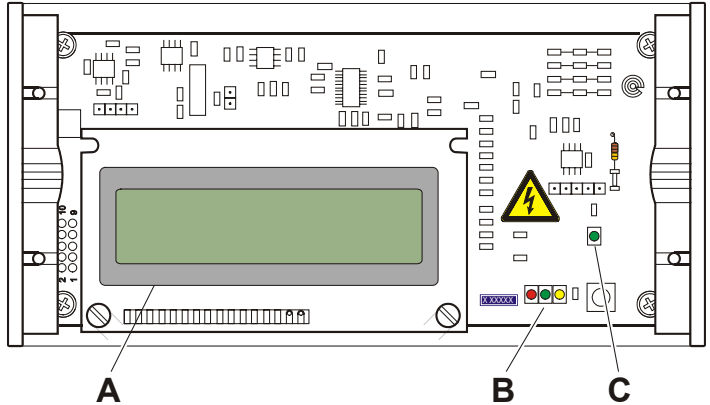

A) LCD display (optional)

The equipment status as well as the status of the monitored phase are provided in a 2-line LC display. Each line can contain 16 characters.

B) LEDs of the phase monitoring

In addition to the optional LCD display, the unit status and status of the monitored phase are also indicated by the three LEDs (red, green, yellow):

C) LED of the self-monitoring (green)

This LED flashes during normal operation and indicates that the self-monitoring feature is active.



Note

The meaning of the LCD display and LED indicators is described in the operating manual.

3 Mechanical Installation

3.1 Transport and unpacking

When transporting the ENS26 isolation unit, pay attention that it is always protected against contact with dirt and damage through impacts and setting down too hard.

Remove the ENS26 from the transport packaging and pull off the protective foil, if necessary.

After transport and before installation, check that the ENS26 isolation unit is in a perfect condition.

3.2 Conditions for installation

The ENS26 is intended for installation on a top hat rail in an electrical cabinet or in a meter cabinet. It cannot be installed anywhere.

The cabinet must be sufficiently large to house the ENS26 and protect the unit from moisture, dust, dirt and heat.

If there is not enough space in the cabinets available, a separate electrical cabinet must be mounted to accommodate the ENS26.



Attention

Never position the electrical cabinet containing the ENS26 above or in the vicinity of a heater. Ensure sufficient ventilation.

The ENS26 should be mounted as near as possible to the mains power outlet and as far as possible from the electricity feeding source.



Note

These measures reduce the effect of voltage increase by the current source.

3.3 Preparing the electrical/meter cabinet

Determine the installation position of the ENS26 on the top hat rail.

Saw a cut-out in the cabinet cover at the installation position of the ENS26 so that you can see the ENS26 and its indicators (LEDs and optional LCD) without opening the cabinet.

The cut-out must have the following dimensions:

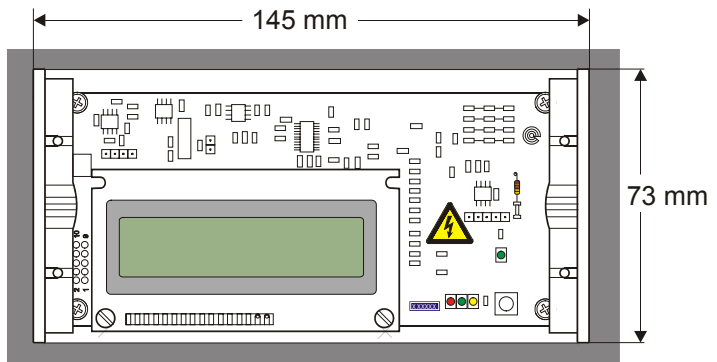

3.4 Mounting on the top hat rail

Set the isolation unit with its top housing holder (A) on the top hat rail and turn it downwards against the top hat rail (B). Use a little force to press on the bottom housing section until the housing holder engages in the top hat rail.

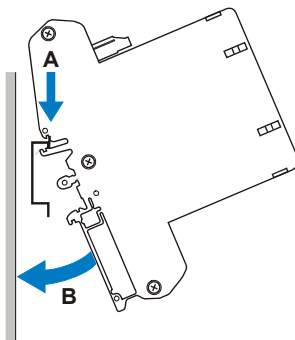

3.5 Removing from the top hat rail

The ENS26 can be removed from the top hat rail.

Insert the tip of a screwdriver in the grooves (A) in the clamps at the ends of the housing. Pull the clamps downwards (B). The ENS26 is released. Remove the ENS26 by turning it a little (C) away from the top hat rail.

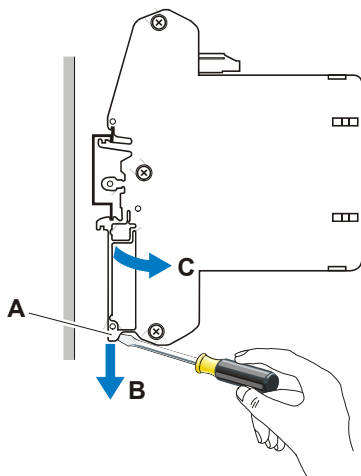
**Attention**

Never remove the ENS26 from the top hat rail using brute force. This could damage the housing holders.

4 Electrical Connections

4.1 Basic configuration

The ENS 26 is connected directly and without any switchin elements between the mains and the feeding point of a phase.



Danger

Connection to the public electricity supply may only be performed by a properly qualified and authorized electrician.

The ENS26 must be protected by a pre-fuse in the respective phase of the mains feed circuit (min. 6 A, max. 25 A). Observe the circuit diagram.

4.2 Circuitry

Check that the mains power lines and power feed line (phase) are not conducting electricity.

Switch the power generator (feeder) and the ENS26 as follows:

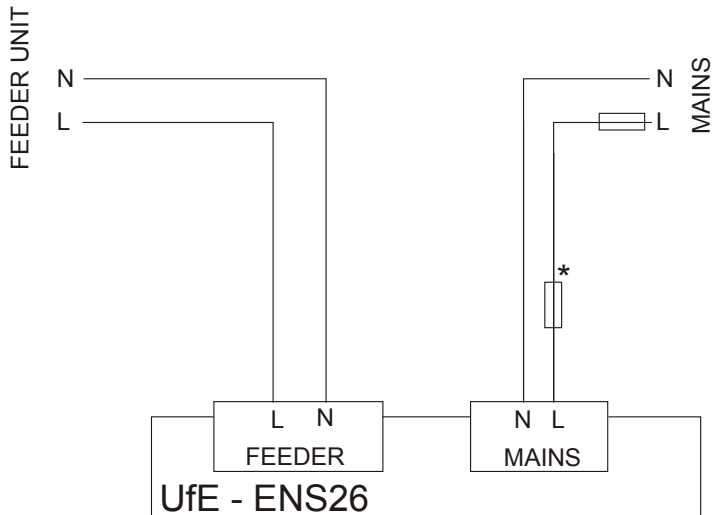

Note

The additional pre-fuse () is only necessary if the direct mains power fuse protection exceeds 25 A.*

The terminals on the ENS26 are arranged as follows:

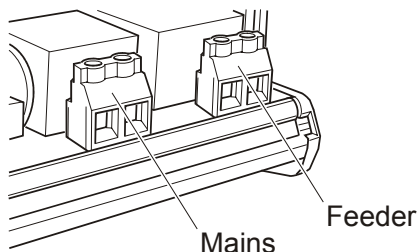

Attention

The ground conductor should always bypass the unit. The neutral conductor MUST be connected to the ENS26 otherwise the unit may be damaged.

If the ENS26 is switched on and off by means of a system control unit, the phase connection (L) of the ENS26 can be switched by means of a relay.



Note

When switching on via a relay, the delay until the contactors are activated can be up to 30 seconds because the ENS26 must test the power feed conditions again.

4.3 Disconnection

Switch off the power supply to the mains power lines and the line from the power generator (feeder).

Wait until the isolation unit has removed all the residual voltages.



Danger

The isolation unit can still conduct dangerously high residual voltage some minutes after being switched off. Risk of accident!

Disconnect the mains power lines and the feeder line.

Insulate bare contacts from mains power lines and feeder line.

The ENS26 can then be removed from the top hat rail (also refer to Chapter 3.5).

5 Function Test

5.1 Switching the system on

Switch the isolation unit on first and then the power generator (feeder).
The ENS starts up automatically after switching on the mains supply.
The following appears on the optional LCD display after a successful self-test and mains test:

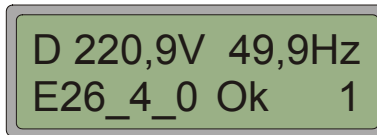

When the voltage, frequency and mains impedance are in the permissible range for 20 to 30 seconds, the relays are triggered and power feed in the public electricity supply begins. The mains power is then monitored.

5.2 Indicators during operation

After switching on, the values for voltage, impedance and frequency are displayed alternately (refer to the Operating Manual).

6 Technical Data

Switched power	max. 5750 W
Own consumption	1.5 W
Housing	Plastic, suitable for assembly on the top hat rail
Overall dimensions (W x H x D)	146 mm x 111 mm x 80 mm
Cut-out dimensions (W x H)	146 mm x 73 mm
Ambient conditions	- 20 °C to + 40 °C, 10 to 90 % relative humidity, non-condensating
Nominal current of power feeder	max. 25 A
The unit disconnects the mains under the following defined conditions (complying with standard DIN VDE 0126):	
Overvoltage (fast shutdown)	> 300 V (response time 0.02 s)
Overvoltage	> 264 V (response time 0.2 s)
Overvoltage (average)	230 V + 10% over 10 minutes
Undervoltage (fast shutdown)	< 130 V (response time 0.02 s)
Undervoltage	< 185 V (response time 0.2 s)
Frequency deviation	+ 0.2 Hz / -2,5 Hz (response time 0.2 s)
RoCoF = Rate of Change of Frequency	> 1 Hz/s
Impedance jump detection	> 0.5 Ohm (response time 0.5 s)